

**i-SPEED SERIES**

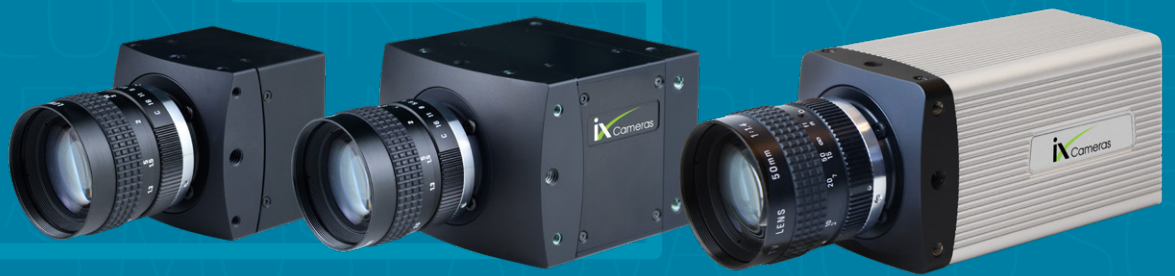

## **i-SPEED<sup>®</sup> 2 SERIES**

Small, lightweight  
high-speed cameras.



# POWERFUL, PORTABLE, AND BUDGET-FRIENDLY

UP TO 16GB ON-BOARD STORAGE

2,500 FPS @ 1280 x 864

225,000 FPS MAX FRAME RATE

POWERFUL i-SPEED SOFTWARE SUITE 2.0

GENICAM COMPLIANT

EXCELLENT LIGHT SENSITIVITY

SHOCK AND VIBRATION RESISTANCE

INTERNAL BATTERY

LIGHTWEIGHT AND COMPACT

VIDEO TRIGGER

MULTIPLE TRIGGER MODES



# Performance specifications

Compact and budget-friendly, the i-SPEED 2 Series cameras are ideally suited for environments where there is limited space for a high-speed camera installation. Outstanding performance features make i-SPEED 2 cameras excellent analysis tools, producing reliable images regardless of low light conditions, temperature extremes, shock and vibration. Choose from four models based on your resolution needs (1MPx to 2.6 MPx), your speed requirements (up to 2.7GPx/sec) and your record durations (up to 16GB RAM).

	i-SPEED 203	i-SPEED 220	i-SPEED 210/211
Throughput (Gigapixels / Second)	2.7	1.5	0.65
Native Image Resolution	1280 x 864	1600 x 1600	1280 x 1024
Maximum speed at full resolution	2,500 fps	600 fps	500 fps
Maximum speed	225,000 fps	204,100 fps	79,500 fps
Record memory, Standard/maximum	8GB / 16GB	2GB / 4GB	<b>210:</b> 2 GB / 4GB <b>211:</b> 4GB / 8GB
Light sensitivity ISO Mono	6,400	1,200	2,500
Light sensitivity ISO Color	5,000		
Minimum shutter speed	1 $\mu$ s	2 $\mu$ s	2 $\mu$ s
Bit depth	8 bits	8 bits	8 bits
Pixel size	13.7 $\mu$ m	8.0 $\mu$ m	14.0 $\mu$ m
Memory partitions		16	16
PC computer camera control	i-SPEED Control One/ Multi-DAQ	i-SPEED Control DX	i-SPEED Control DX
Saved formats	TIFF, JPEG, RAW, IXV, AVI	AVI, JPG, DNG, BMP, PNG, TIFF	AVI, JPG, DNG, BMP, PNG, TIFF
Ethernet connection	1 Gb	1 Gb	1 Gb
Dimensions Inches (L x W x H)	4.7 x 2.6 x 2.6	2.6 x 2.5 x 2.5	<b>210:</b> 2.6 x 2.5 x 2.5 <b>211:</b> 3.6 x 3.7 x 2.7
Dimensions mm (L x W x H)	120 x 65 x 65	66 x 64 x 64	<b>210:</b> 66 x 64 x 64 <b>211:</b> 92 x 94 x 69
Lens mounts	Normal	Normal	Normal
G-shock rating		100G (optional)	100G (optional)
Battery equipped			Yes (211)

# i-SPEED 203—performance in a compact form factor



## Sensor

Light-sensitive CMOS sensor delivers excellent light sensitivity and superb image quality with a high level of detail to record and replay most life sciences, robotics, and machinery applications in slow motion.

## Compact and robust

The i-SPEED 203 puts slow motion in the palm of your hand. The small form factor fits where other cameras cannot: microscope optical mounts, engine compartments, assembly lines, mounted on machinery, and more.

## Up to 16GB memory

With memory levels of 8GB and 16GB, the i-SPEED 203 can capture events of extended durations.

## Powerful control software

i-SPEED Control One or Control Multi-DAQ (for i-SPEED 203) has been developed to handle large amounts of data, fast transmission, and ultra-slow motion in captured videos. Menus and workspace are structured for intuitive workflow. Define your trigger setting with just one click, adjust video playback speed, and mark your videos with helpful information such as a time stamp, frame rate, resolution, or trigger information. The user-friendly control software is suited for a wide range of video applications, including manufacturing processes, R&D, testing, robotics, biomechanics, and sports science.

## Multiple trigger modes

Trigger events manually, choose post-trigger burst mode, or the optional video trigger.

## GenICam compliant

The i-SPEED 203 can be controlled with the global standard GenICam generic programming interface for industrial cameras.

## Video trigger

The i-SPEED Software Suite 2.0 video trigger system, available with Control Multi-DAQ, monitors changes in the luminance of a selected area of the scene and triggers when the changes exceed defined levels.

Frame Speed	Resolution	8GB	16GB
2,500	1280x864	248	4.96
2,813	1280x768	248	4.96
3,000	1280x720	248	4.96
4,219	1280x512	248	4.96
4,501	1280x480	248	4.96
9,002	1280x240	248	4.96
16,879	1280x128	248	4.96
33,758	1280x64	248	4.97
67,516	1280x32	248	4.97
90,022	1280x24	248	4.97
180,044	1280x12	248	4.97
225,000	1280x8	2.98	5.96

## 203 Quantum Efficiency—Color

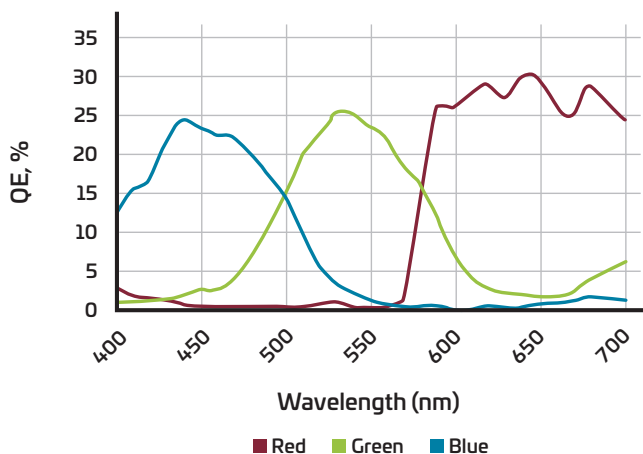

## 203 Quantum Efficiency—Mono

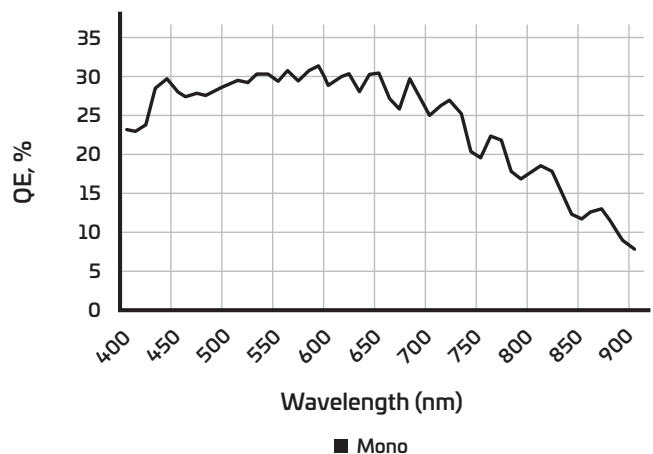

# Our cameras set us ahead. Our software sets us apart.



With both versions of the i-SPEED Software Suite 2.0—Standard and Premium—you will experience unparalleled features and the most complete set of functions with a modern and intuitive GUI. Control your camera via Gigabit Ethernet connection—load and control single and multiple camera configurations or connect remotely for uninterrupted access to restricted areas.

## Two levels to suit your specific application requirements

- Control ONE: Control a single camera from a laptop or PC.
- Control Multi-DAQ: Control multiple cameras and/or synchronize with data acquisition devices.

## Local languages

To accommodate our worldwide customer base, the i-SPEED Software Suite 2.0 will be available in local languages to meet the needs of our global customers.

## Video trigger

The latest feature of the i-SPEED Software Suite 2.0, this functionality allows the user to define trigger levels through a manual mode or choose auto mode and have the software calibrate trigger levels. A real-time track mode has been added for triggering the camera in a dynamically changing environment such as cloud cover.

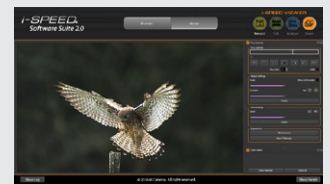
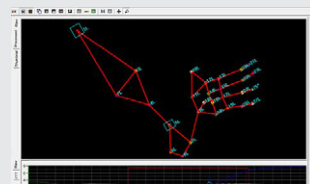

### Record

Customized connection and crow's-nest layout window

- Instantly sync and record from multiple cameras.
- Choose multiple configurations of a single camera, or quickly configure a new camera and new capture settings from inside the simplified connection control panel.

### Edit

Renderless editing suite—i-SPEED Movie Maker features virtually no render lag

- The world's only editing software designed specifically for high-speed video
- Focuses on frame rate and video speed
- Available with Control Multi-DAQ

### Analyze

Your i-SPEED camera becomes a precision measurement device with ProAnalyst® from Xcitex Inc., the world's most advanced motion analysis software

- Analyze, graph, and output speed, acceleration, fluid dynamics, PIV, and more with optional toolkits.
- Available with Control Multi-DAQ

### Share

Play just about anything

- View and import saved files directly from the camera.
- Align and play multiple file types.
- Load and control the video and playback speed all without load times—load and play multi-gigabyte files instantly.

## Software Developer's Kit (SDK)

iX Cameras will provide the SDK kit and the technical support to customize the software to meet your specific applications needs. We will work with you to integrate program commands into your own software to allow you full control of all i-SPEED 203 camera functions and features.

# i-SPEED Software Suite 2.0 features



## *i-SPEED* 203

	Standard Bundle	Premium Bundle
<b>Bundled Software</b>		
Control ONE	■	
Control Multi-DAQ		■
Viewer	■	■
Movie Maker		■
ProAnalyst® by Xcitex Motion Analysis Software (see page 7 for details)	Introductory	Lite
<b>Main Functions</b>		
Language	Local Languages	Local Languages
Simple Mode	■	■
Customizable Workspaces	■	■
Check for Updates	■	■
<b>Camera Connect</b>		
Single Camera Control	■	■
Multi-Camera Control		■
Sync DAQ Control		■
Camera Naming / Positioning / Appearance	■	■
Crow's Nest Test Set-Up View	■	■
Real-Time Camera Health Monitoring System	■	■
<b>Camera Capture</b>		
Low Light Mode	■	■
Calibration Snapshot for DIC / PIV	■	■
Sync Modes	Normal	Normal
Sync	Master / Slave	Master / Slave
Trigger Modes	Normal (Circular)	Normal (Circular), BROCC
Video Trigger		■
Software Trigger	■	■
TTL Trigger	■	■
i-CHEQ	■	■
<b>Video Review</b>		
Time Zoom	■	■
Bookmarks	■	■
Measure Window (Angles, Distances)	■	■
Video Processing	■	■
<b>Measure (see next page for details)</b>		
Linear, Distance, and Velocity	■	■
Angular, Angle, and Angular Velocity	■	■
<b>Save</b>		
File Formats	TIFF, JPG, RAW, IXV, AVI	TIFF, JPG, RAW, IXV, AVI
File Name Sequencing for Ingestion Into 3rd Party Software	■	■

# ProAnalyst® Motion Analysis Software by Xcitex

ProAnalyst	Introductory	Lite
<b>File Management</b>		
AVI, WMF, ASF, CINE, MPED-1, MOV, and MP4 Files	■	■
BMP, JPG, PNG, TIFF Image Sequence Compatibility	■	■
Project-Based File Management	■	■
Video Explorer	■	■
Pack / Unpack Projects	■	■
<b>Image Calibration and Processing</b>		
Image Processing	■	■
Image Filtering		Limited
Video Timeline	■	■
Layered Display and Editing	■	■
2-D Scene Calibration	■	■
Perspective and Multi-Plane Scene Calibration		■
<b>Video Analysis</b>		
2-D Feature Tracking	■	■
Number of Auto-Track Features	1	256
Number of Manual Track Points	32	256
Real-Time Annotations of Distance and Angle Between Features		■
<b>Graphing and Computation</b>		
Graphing Within ProAnalyst		Limited
<b>Notes and Reports</b>		
External Data Import		■
Tracking Data Export to C3D, Diadem, Excel, MATLAB	Limited	■
Video Frame, Data Point, and Global Notes		■
Image Annotation	■	■

ProAnalyst Professional and 3-D Professional	Professional	3-D Professional
<b>Image Calibration and Processing</b>		
3-D Manager		■
3-D Scene Calibration		■
Lens Distortion Correction	■	■
<b>Video Analysis</b>		
Image Stabilization Toolkit*	Optional	Optional
Particle Counting, Sizing, and Tracking Toolkit*	Optional	Optional
Contour / Edge Analysis Toolkit*	Optional	Optional
Particle Image Velocimetry Toolkit	Optional	Optional
Impact Excursion Toolkit	Optional	Optional
Biological Cell Tracking Toolkit	Optional	Optional
1-D Line Tracking	■	■
3-D Measurement and Analysis		■
<b>Graphing and Computation</b>		
One-Click FFT	■	■
2-Axis Graphing	■	■
3-Axis Graphing	■	■
3-D Graphing of Trajectories from 3-D Manager	■	
Data Filtering	■	■
<b>Notes and Reports</b>		
HTML, PowerPoint, and Print-Ready Report Generator	■	■

\*Included in Professional Ultimate Bundle

## Upgrade Options

- From **Introductory** to **Professional** Edition
- From **Introductory** to **Professional Ultimate Bundle**
- From **Lite** to **Professional** Edition
- From **Lite** to **Professional Ultimate Bundle**
- From **Professional** to **3-D Professional** Edition
- From **Professional Ultimate Bundle** to **3-D Professional Ultimate Bundle**
- **ProAnalyst** is sold separately for the i-SPEED 210/211/220 cameras

# i-SPEED Software Suite 2.0 video trigger system



A real-time video trigger system has been added to the i-SPEED® Software Suite—for when you can't use a wired trigger, or when you want to use the event itself to trigger the camera recording.

This new system works by monitoring changes in luminance value of a defined location in the camera scene. This feature is available only for the i-SPEED 203 running Control Multi-DAQ.

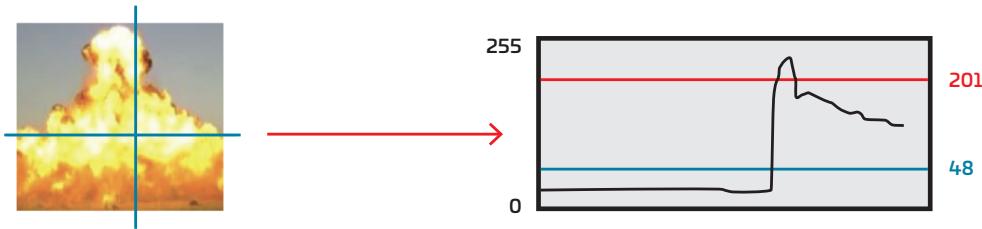

The brightness of the pixel under the reticle is plotted on a graph and if the value goes above or below a user set value then the camera will be triggered.

## The new video trigger system has three options, depending on the application.

### Auto Mode

Quick and simple setup

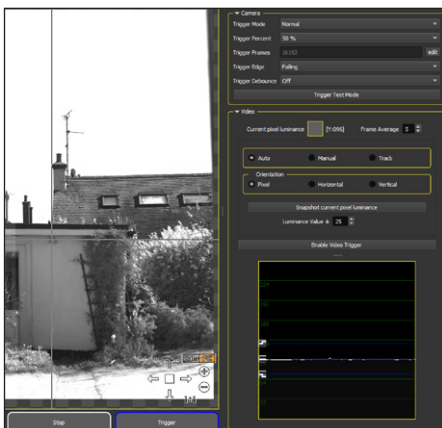

Auto mode is a quick and simple way to set up a Video Trigger:

1. Place the reticle on the location where the movement is expected.
2. Snapshot the current pixel luminance.
3. Click **Enable Video Trigger**.

If the value changes higher or lower than the default thresholds of 25, the camera will trigger.

Note: The thresholds can be modified to make the trigger more or less sensitive to luminance changes.

### Manual Mode

User-definable trigger levels for more control

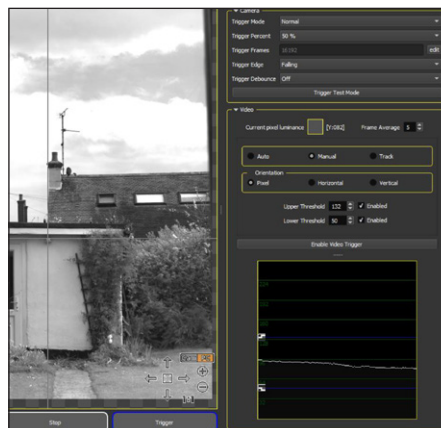

Manual mode provides more control than Auto. For example, the user may only want to run with an upper threshold (trigger on brighter, not darker).

1. Place the reticle on the location where movement is expected.
2. Set or disable the Upper Threshold.
3. Set or disable the Lower Threshold.
4. Click **Enable Video Trigger**.

If the value meets any enabled threshold, a trigger event will occur.

### Track Mode

For dynamic changing environments

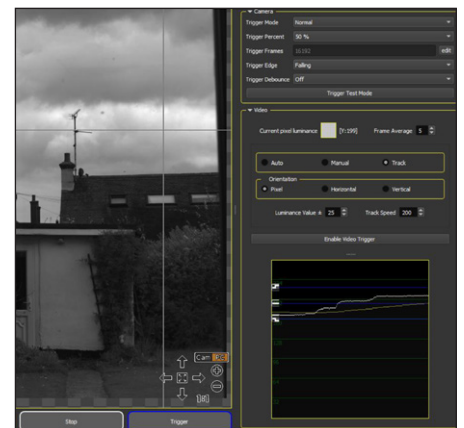

The Track mode allows the luminance to change slowly without triggering the camera, and only allows a trigger to occur when the luminance changes quickly. An example for use is in an outdoor environment with cloud cover where the ambient brightness will vary slowly.

1. Place the reticle on the location where movement is expected.
2. Set the Upper and Lower Threshold.
3. Set the Track Speed.
4. Click **Enable Video Trigger**.

If ambient brightness changes are too fast and create an unwanted trigger event, then the Track speed can be lowered, allowing the tracking to move more quickly.



## IMAGER

---

Frame rate at full resolution	2,500 fps
Shutter	1 $\mu$ s
Spectral bandwidth	420-700 nm
Maximum resolution	1280 x 864
Maximum frame rate	225,000 fps
Sensor diagonal	21.15 mm
Pixel size	13.7 $\mu$ m square
Bit depth	10 bit
Light sensitivity	6,400 mono / 5,000 color

## SYNCHRONIZATION and CAPTURE

---

Memory	8 GB / 16 GB
Video	IXV, AVI (compressed or uncompressed)
Image sequence	TIFF, JPEG, RAW

## PHYSICAL and ENVIRONMENTAL

---

Dimensions, inches	2.6 (W) x 2.6 (H) x 4.7 (L)
Dimensions, mm	65 (W) x 65 (H) x 120 (L)
Weight	1.1 lbs (500 g) without lens
Input voltage	10-30 VDC
Power consumption	17 W max
Mounting	1/4-20
Lens options	C mount / FG mount
Temperature °F	41 to 122 operation
Temperature °C	5 to 50 operation

## CONNECTIVITY

---

Network	1 Gb RJ45
Power input	5 pin female connector
Trigger	External signal / switch triggering
Input/output	16 pin female
Ethernet	1 Gb
Remote control	Via supplied software

## PURCHASING OPTIONS

---

Sensor	Color / Mono
Memory	8 GB / 16 GB
Warranty	1 year standard parts and labor



# i-SPEED 210/211/220— compact, versatile, easy to use



The i-SPEED 210, 211, and 220 are economical high-speed cameras for real-world situations where access, portability, and rapid deployment matter. Providing a balance between cost, speed, resolution, and compact size, these cameras are ideal for budget-conscious test laboratories, production lines, and test facilities.

## Sensor

High-sensitivity CMOS sensors provide 1.3 million pixels of resolution at 500 fps (models 210 and 211) and 2.6 megapixel resolution at 600 fps (model 220). Combined with the global exposure shutter, these cameras produce images that are ideal for microscopy, robotics, auto-crash testing, graphics inspection, 3-D biomechanics, sports, web inspection, and more.

## Compact, lightweight, easy to use

Whether attached to machinery or mounted on a tripod, the small form factor of the i-SPEED 2 Series cameras fits where other cameras cannot.

## Control DX software

i-SPEED Control DX software provides a complete user-friendly interface for recording, playback, and editing of i-SPEED 2 high-speed videos. This powerful camera control software has been developed specifically to handle large amounts of data, fast transmission, and ultra-slow motion. Control DX is ideal for a wide range of video applications including manufacturing and process automation, quality assurance testing, research and development, biomechanics, and sports.

**Camera connect** features allow the user to connect to one or more cameras and save user profiles in local languages.

**Camera capture** features include Low Light mode, digital gain, and dynamic range adjustment.

**Video review** provides multi-camera playback, jump to trigger frame, and video clip creation.

**Save and export** in a variety of formats.

**Additional features** include Image Processing, and a variety of recording, sync, and trigger modes.

## Internal battery

The i-SPEED 211 comes with an internal battery making this camera ideal for untethered portable field work. Charge, unplug, and record. Battery life is 1 hour while recording and 1.5 hours while in standby mode.

## Trigger modes

i-SPEED 2 models running Control DX software have two trigger modes, Normal and Burst. Triggering can be accomplished via software, external trigger switch, or the trigger button on the model 211.

## GenIcam compliant

All i-SPEED 2 Series cameras can be controlled with the global standard GenIcam generic programming interface for industrial cameras.

## Performance options

### Video trigger

i-SPEED Control DX software provides a video trigger option for the 210, 211, and 220 models. The video trigger window works like a sensor. When video triggering is activated, a reference image of the current scene is stored. In all following frames, the video trigger window is compared to the reference image. Depending on the trigger settings for gray difference and relative object size, changes in the window will trigger the camera.



## Memory upgrade

Capture extended-duration events with memory levels that can be upgraded from 2GB to 4GB (models 210 and 220), or 4GB to 8GB (model 211).

## Hi-G packaging

For use in harsh environments, select the Hi-G option. i-SPEED 2 cameras with Hi-G are certified to 100G shock and 20G vibration for the most physically demanding applications.

## IRIG

Connect the i-SPEED 211 to an IRIG-B generator to synchronize your camera's timing.

## Segmented memory

Choose this option to partition the camera's internal memory to a maximum of 16 buffers.

# i-SPEED 210/211/220 performance



## *i-SPEED* 210/211

Frame Speed	Resolution	2GB	4GB	8GB
500	1280x1024	3.3	6.5	13.1
700	1280x720	3.3	6.7	13.3
1,000	1280x512	3.3	6.5	13.1
1,250	800x600	3.6	7.2	14.3
1,850	640x480	3.8	7.6	15.1
2,000	512x512	4.1	8.2	16.4
5,650	320x240	4.9	9.9	19.8
18,500	128x100	9.1	18.1	36.3
79,500	128x10	21.1	42.2	84.4

## *i-SPEED* 220

Frame Speed	Resolution	2GB	4GB	8GB	16GB
600	1600x1600	14	2.8	5.6	11.2
1,000	1600x900	1.5	3.0	6.0	11.9
1,150	1280x1024	14	2.8	5.7	11.4
1,400	1024x1024	1.5	2.9	5.8	11.7
1,640	1280x720	14	2.8	5.7	11.4
2,850	800x600	1.6	3.1	6.3	12.6
4,450	640x480	1.6	3.1	6.3	12.6
5,000	512x512	1.6	3.3	6.5	13.1
14,750	320x240	1.9	3.8	7.6	15.2
43,500	128x128	3.0	6.0	12.0	24.1
204,100	128x10	8.2	16.4	32.9	66.0

## 210/211 Quantum Efficiency

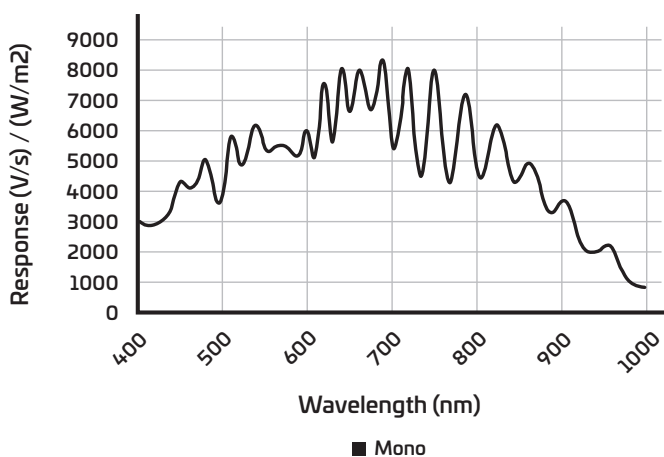

## 220 Quantum Efficiency

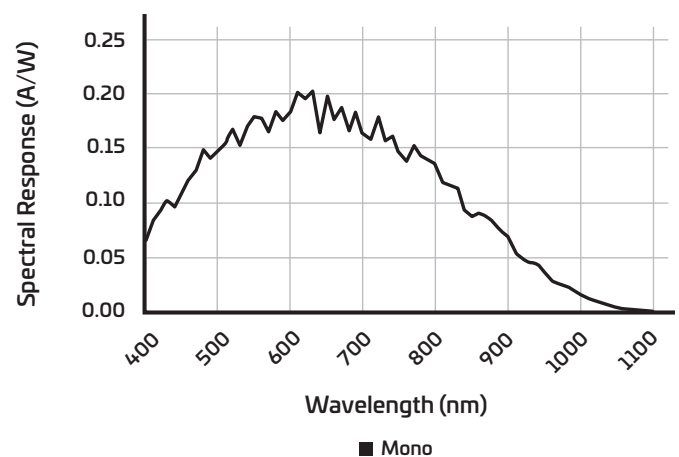

# Specifications

## *i-SPEED* 210/211

### IMAGER

Frame rate at full resolution	500 fps (1,750 fps in quad mode)
Shutter	Global electronic shutter: 2 µs to 1 s
Spectral bandwidth	400 - 900 nm
Amplification	Digital gain 1 - 4 in 8 steps
Maximum resolution	1280 x 1024
Maximum frame rate	79,500 fps
Sensor diagonal	Size 22.9 mm
Pixel size	14 µm square
Bit depth	10 bit
Light sensitivity	2,500 mono / 2,000 color

### SYNCHRONIZATION and CAPTURE

210 Memory	2 GB / 4 GB
211 Memory	4 GB / 8 GB
Memory segments	16
Video	AVI (JPG, BMP)
Image sequence	TIFF, BMP, JPG, DNG, PNG

### PHYSICAL and ENVIRONMENTAL

210 Dimensions inches	2.5 (W) x 2.5 (H) x 2.6 (L)
Dimensions mm	64 (W) x 64 (H) x 66 (L)
Weight	0.66 lbs (300 g) without lens
211 Dimensions inches	3.7 (W) x 2.7 (H) x 3.6 (L)
Dimensions mm	94 (W) x 69 (H) x 92 (L)
Weight	2.00 lbs (900 g) without lens
Input voltage	10 - 30 VDC
Power consumption	210 / 7.5 w max 211 / 15 w max
Mounting	¼-20
Battery charge	Recording: 1 hr, standby: 1.5 hr*
Lens options	C mount / F mount / FG mount
G shock	Hi-G 100 G shock, 10 G vibration
Temperature °F	41 to 113 operation
Temperature °C	5 to 45 operation
Ethernet	1 Gb
Remote control	Via supplied software

### CONNECTIVITY

IRIG input	B synchronization*
Network	1 Gb RJ45
Power input	6 pin female connector
Trigger	External signal/switch triggering
Input/output	8 pin female I/O module*
Trigger modes	Video trigger, burst trigger mode

### PURCHASING OPTIONS

Sensor	Mono
210 Memory	2 GB / 4 GB
211 Memory	4 GB / 8 GB
Package	Standard / Hi-G rated
Warranty	1 year (std)/2 yr

\*Model 211 only

## *i-SPEED* 220

### IMAGER

Frame rate at full resolution	600 fps
Shutter	Global electronic shutter: 2 µs to 1 s
Spectral bandwidth	400 - 900 nm
Amplification	Digital gain 1 - 2 in 3 steps
Maximum resolution	1600 x 1600
Maximum frame rate	204,100 fps
Sensor diagonal	size 18.1 mm
Pixel size	8 µm square
Bit depth	8 bit
Light sensitivity	1,200 mono / 1,000 color

### SYNCHRONIZATION and CAPTURE

Memory	2 GB / 4 GB
Memory segments	16
Video	AVI (JPG, BMP)
Image sequence	TIFF, BMP, JPG, DNG, PNG

### PHYSICAL and ENVIRONMENTAL

Dimensions inches	2.5 (W) x 2.5 (H) x 2.6 (L)
Dimensions mm	64 (W) x 64 (H) x 66 (L)
Weight	0.66 lbs (300 g) without lens
Input voltage	10 - 30 VDC
Power consumption	220 = 7.5 W max
Mounting	¼-20
Lens options	C mount / F mount / FG mount
G shock	Hi-G 100 G shock, 10 G vibration
Temperature °F	41 to 113 operation
Temperature °C	5 to 45 operation
Ethernet	1 Gb
Remote control	Via supplied software

### CONNECTIVITY

Network	1 Gb RJ45
Power input	6 pin female connector
Trigger	External signal/switch triggering
Trigger modes	Video trigger, burst trigger mode

### PURCHASING OPTIONS

Sensor	Mono
Memory	2 GB / 4 GB
Package	Standard / Hi-G rated
Warranty	1 year (std)/2 yr

# i-SPEED 203 dimensions

With many applications, the camera is a component in the overall solution. While commercially available accessories can fulfill most requirements, there are always some situations that require a bit extra. This may be as simple as a bracket to mount an accessory to the camera, or as complex as a full OEM system integration. Whatever the requirement, accurate and complete interface data is a must. As such, iX Cameras is pleased to provide another first in our industry by opening access to the CAD model data for the exterior of our cameras.

For more information, please visit our [Cameras CAD Models](#) page.

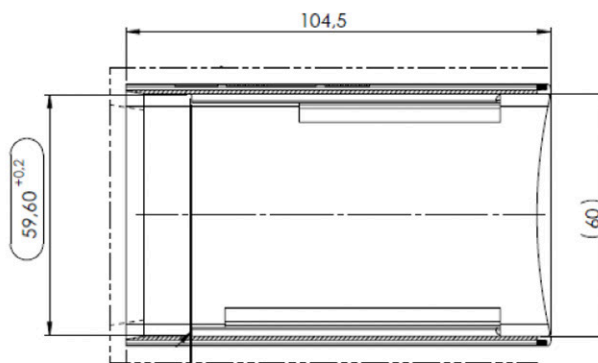
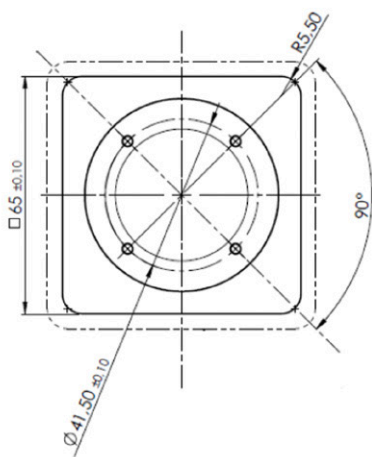
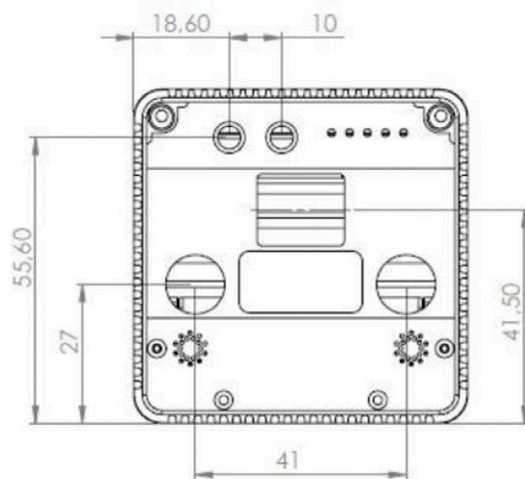
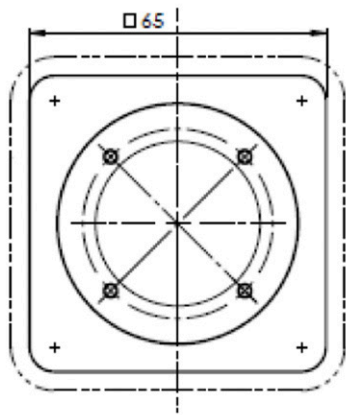

# i-SPEED 210/220 dimensions

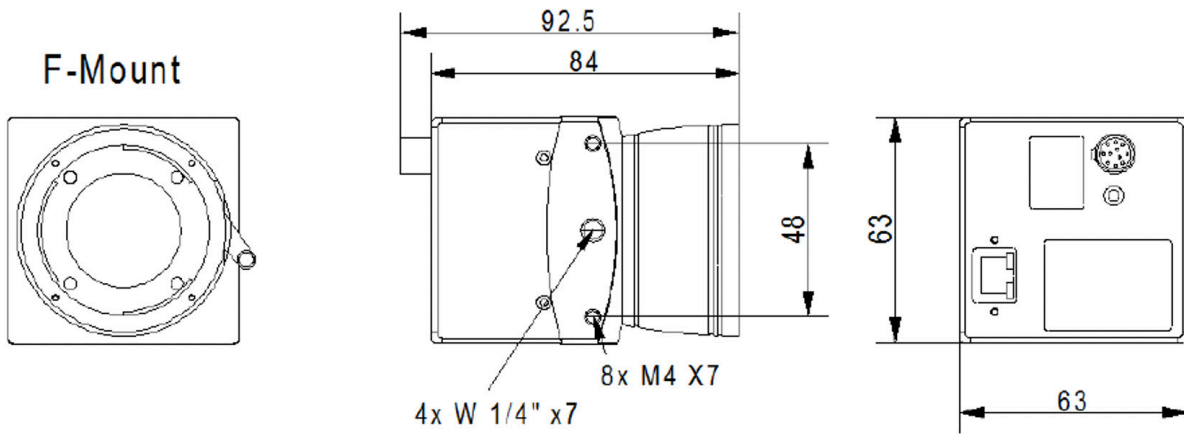
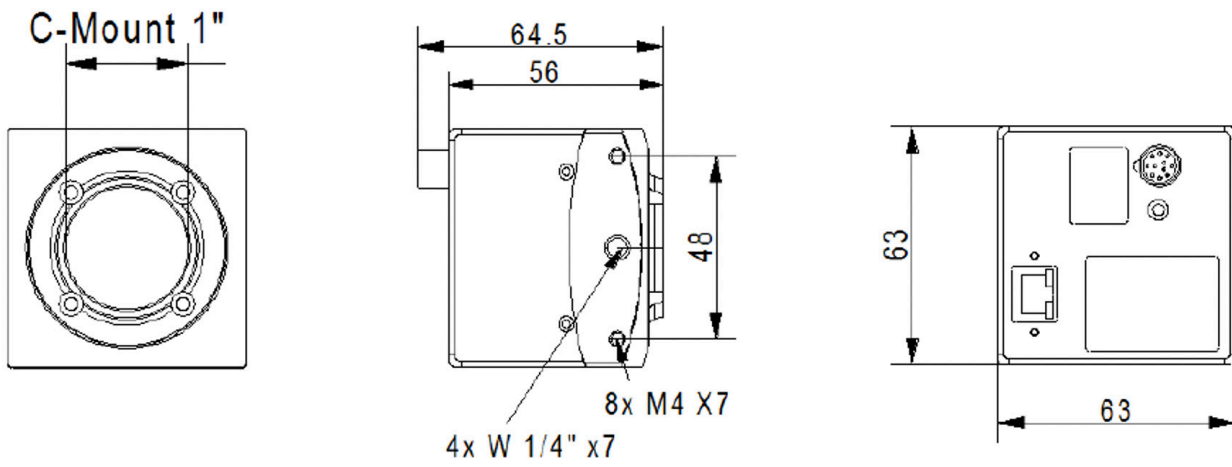

# i-SPEED 211 dimensions

**C-Mount**

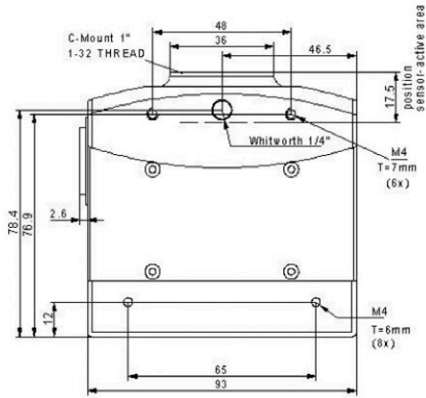

**F-Mount**

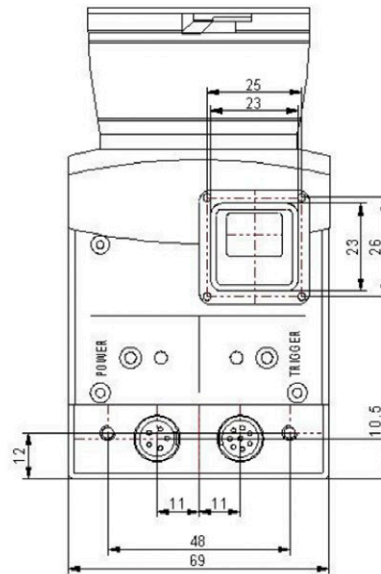
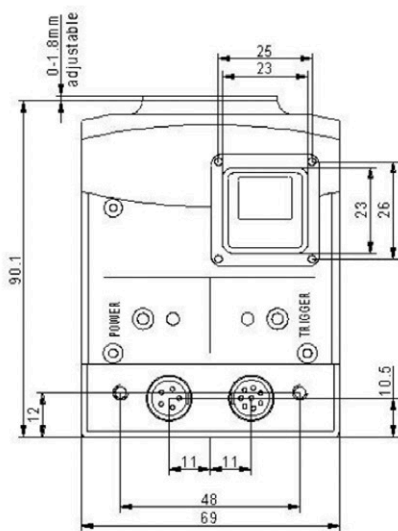
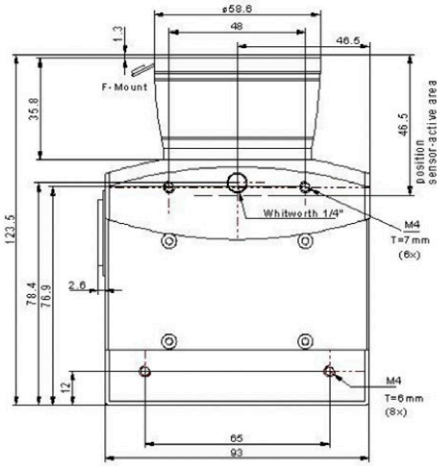

# Advanced high-speed cameras for any application

The i-SPEED 2 Series bring portability and power with high performance, lightweight, compact high-speed cameras suited for a wide range of applications.

**Assembly Line**

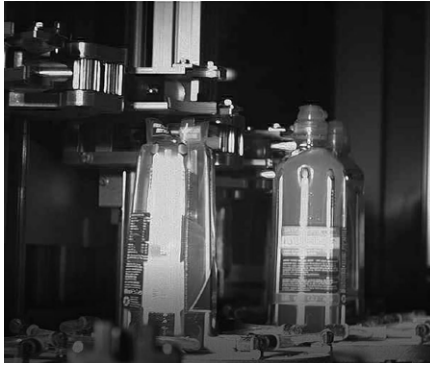

**Automotive**



**Biomechanics**



**Drop Test**



**Industrial**



**Scientific Research**

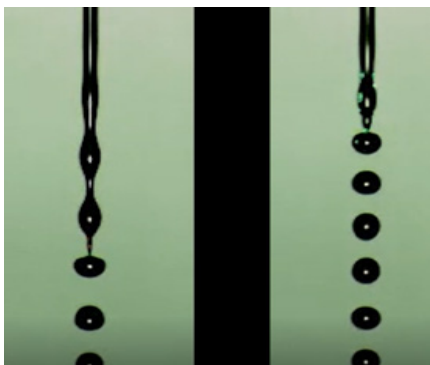

**Sports**

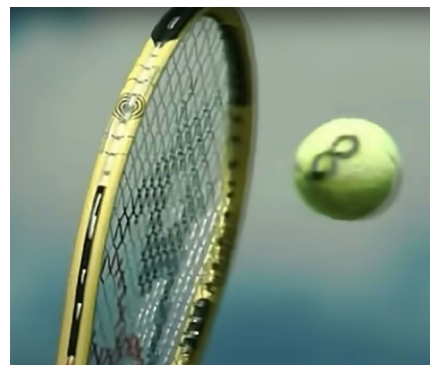



# A legacy built on innovation



iX Cameras is a world-leading technology and product company specializing in the field of high-speed (slow motion) imaging. Based on proprietary innovative technologies, we design, build and sell cutting-edge ultra-fast cameras and software for a wide range of advanced scientific research applications. Our commitment to innovate and push the boundaries of high-speed video science drives our development of technically superior and easy-to-use products that our customers demand to attain the highest scientific achievements and creativity. The innovation of our i-SPEED brand of cameras is backed by our world-class service and support teams, ensuring our customers' success.

For over a decade, thousands of i-SPEED brand cameras were developed and sold by Olympus until the spinoff of the product development group in 2014. Today, the same development team from Olympus, combined with new camera and software industry veterans, continues to design innovative state-of-the-art i-SPEED cameras under the iX Cameras name.

## iX Innovation Centre

We built the Innovation Centre at our Rochford, UK facility to create an environment combining the latest in academic research, industry know-how and practices, and our own engineering team to advance high-speed imaging technology. This holistic collaborative approach brings together people, ideas, and skills from different disciplines and industries to help us design, build, and service the most powerful, feature-rich, and easy to use cameras in the marketplace.



## Worldwide Sales Network

iX Cameras sells its products through a worldwide network of dealers. To find the dealer nearest you, please visit our website at [ix-cameras.com](http://ix-cameras.com)

### United Kingdom

Bradley House  
Locks Hill  
Rochford Essex, SS4 1BB  
T: +44 (0) 1702 540 669

### United States

8 Cabot Road  
Suite 1800  
Woburn, MA 01801  
T: +1 339 645 0778

### China

Room 605, Building 8  
No 365, Chuanhong Road  
Pudong New District  
Shanghai, 201323  
T: +86 186 215 60553

### India

C-207, Twin Arcs  
Legacy Life Spaces, Punwale Bazar  
Punawale, Pune-411033  
Maharashtra  
T: +91 955 256 5021

[info@ix-cameras.com](mailto:info@ix-cameras.com)

[ix-cameras.com](http://ix-cameras.com)

To find the iX Cameras sales partner nearest you, visit our [Worldwide Distribution](#) page.